



The **IK HC 1.5 professional sprayer** has been designed and manufactured with materials of maximum resistance to be used with vegetable and animal oils, hydrocarbon-based solvents, lubricants and petroleum products.

It is ideal for use in the automotive industry for tasks such as brake cleaning, removal of tar stains and removal of silicones in tasks prior to painting the bodywork.

IK HC 1.5 is optimal for industrial applications of protection, degreasing and lubrication, as well as wood treatment.



### Sectors in which to use

- Building
- Industry and maintenance
- Automotive and detailing
- Pest control

### Products with which to use

**optimal** Solvent-based pesticides, oils, solvents and petroleum by-products



IK HC

Oils, solvents and petroleum by-products	✓
Acids	✗
Alkalis and ketones	✗
Alcohols	L
Disinfectants	✗
Solvent based pesticides	✓
Neutral products	✓

L *Optimal* ✓ *Limited* ✗ *Not valid*

### Technical information

Technical information	HC 1.5
VALVE	Tared at 2,5 bar / 36 psi despresurizable
STANDARD NOZZLES	Adjustable conical nozzle
USEFUL CAPACITY	1l. - 35 Oz
TOTAL CAPACITY	1.50l. - 50 Oz
LITRES/MIN. 3 BAR	0.7l/min - 0.18 gal/min
GROSS WEIGHT	0.60 kg - 1.32lbs.
NET WEIGHT	0.46 kg - 1.02 lbs.

### Logistics data

Logistics data	HC 1.5
CODE	8.17.74
EAN	84.14685.10174.7
CONDITIONING	6 units
UNITS PER PALLET	90 units
DIMENSIONS PER PALLET	1200 x 800 x 960

### Functional information



Safety valve with depressurisation option



Protective sleeve for valve chamber

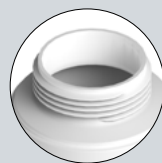

Large opening easy filling



Translucent tank with level indicator





## ACCESSORIES



Personalize your sprayer adapting it to your application needs (height, hard-to-reach areas...)



**FLEX PIPE 0.25 M**  
Reference 8.38.77.810

A flexible pipe of 0.25 m for applications in places that are hard to reach. Do not use it with acid or corrosive products.



**13.5 CM LANCE**  
Reference 8.38.11.831

13,5cm lance in fibreglass for applications of difficult access (inside and outside corners, etc.). This accessory needs an adaptor M18 for the IK HC 1,5 product.



**M18 HC ADAPTER**  
Reference 8.17.74.602

Adapter for HC model that allows coupling of different nozzles and accessories.



**CONTENT IDENTIFIER IK 1.5/2**  
Reference 8.16.71.900

Colour caps to identify deposit content between devices of the same line.

## MAINTENANCE KITS



Keep your sprayer always ready and get maximum performance

**IK HC 1.5 MAINTENANCE KIT**  
Reference 8.17.74.874



CHAMBER VALVE N. 165	8.38.05.314.1
ROUND GASKET Ø15 N. 603	2.23.99.43.916
ROUND GASKET AN-5 N. 607	2.23.16.905
ROUND GASKET N. 098	2.23.16.990
ROUND GASKET N. 1269	2.23.16.128
SHAFT WITH JOINT N. 1284	8.17.74.603



## SPARE PARTS



Extend the service life of your sprayer easily replacing parts

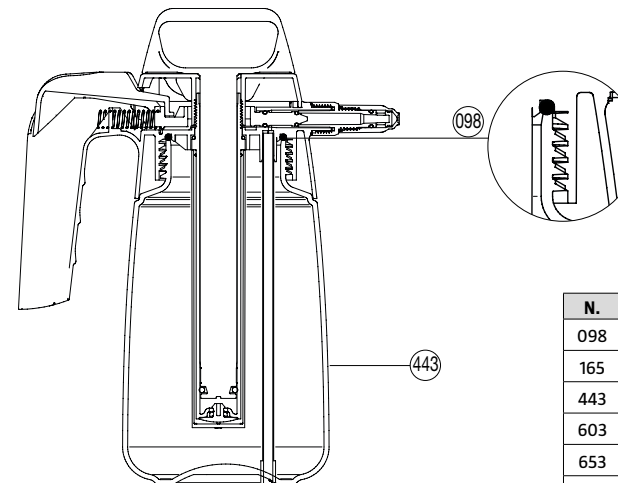

N.	COD.	Q	SPARE PARTS NAME
098	2.23.16.990	1	ROUND GASKET
165	8.38.05.314.1	1	CHAMBER VALVE
443	8.17.71.301	1	TANK
603	2.23.99.439.16	1	ROUND GASKET Ø15
653	8.28.27.320	1	TUBE WITH FILTER
1068	8.17.74.305	1	CYLINDER GUARD
1069	8.17.74.601	1	M-12 ADAPTER WITH ADJUSTABLE CONICAL NOZZLE
1070	8.17.74.801	1	COMPLETE CHAMBER
1284	8.17.74.603	1	SHAFT WITH JOINT
	8.17.74.200	1	INSTRUCTION SHEET
	8.17.74.201	1	PACKAGING

