



The **IK INOX/SST 6-10 sprayers** are characterized by their great robustness, ease of use and quality of materials. They have been created for use with vegetable and animal oils, low-viscosity release oils, neutral (non-chlorinated) cleaning agents, hydrocarbon-based solvents, lubricants and petroleum products.

The IK INOX/SST 10 includes a connector for compressed air.



Sectors in which to use

- Building
- Cleaning and disinfection
- Industry and maintenance
- Pest control

Products with which to use

optimal Solvent-based pesticides, oils, solvents and petroleum by-products



CHEMICAL PRODUCT TABLE

IK INOX/SST

Oils, solvents and petroleum by-products	✓
Acids	✗
Alkalis and ketones	✗
Alcohols	L
Disinfectants	✓
Solvent based pesticides	✓
Neutral products	✓
High pressure	✓
Hot chemicals	✓
Weather resistance	✓

L *Optimal* ✓ *Limited* ✗ *Not valid*

Technical information

Technical information	INOX 6	INOX 10
VALVE	Tared at 6 bar / 88 psi despresurizable	
HOSE	1.8 m / 70.8 inches	
STANDARD NOZZLES	Adjustable conical nozzle and fan	
LANCE	50 cm / 19,6 inches stainless steel	
USEFUL CAPACITY	6L - 1.58 U.S. Gals.	10L - 2.64 U.S. Gals.
TOTAL CAPACITY	9L - 2.4 U.S. Gals.	13L - 3.4 U.S. Gals.
LITRES/MIN. 3 BAR	0.7 l/min. - 0.18 gal/min.	
GROSS WEIGHT	4.4 kg - 9.7 lbs.	4.9 kg - 10.8 lbs.
NET WEIGHT	4 kg - 8.8 lbs.	4.5 kg - 9.9 lbs.

Logistics data

Logistics data	INOX 6	INOX 10
CODE	8.32.73	8.32.74
EAN	84.14685.10191.4	84.14685.10192.1
CONDITIONING	1 unit	
UNITS PER PALLET	24 units	16 units
DIMENSIONS PER PALLET	1200 x 800 x 1180	1200 x 800 x 1060

Functional information



Stainless steel handle and lance



Integrated funnel in tank



Safety valve with depressurisation option



Pressure gauge



Carrying straps for over shoulder transport

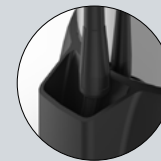

Parking for lance

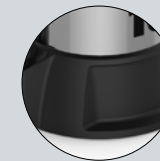

Stable base with footrest



Parking for the chamber during filling



ACCESSORIES



Personalize your sprayer adapting it to your application needs (height, hard-to-reach areas...)



FLEX PIPE 0.5 M
Reference 8.38.77.813

A flexible pipe of 0.5 m for applications in places that are hard to reach. Do not use it with acid or corrosive products.



FLEX PIPE 0.25 M
Reference 8.38.77.810

A flexible pipe of 0.25 m for applications in places that are hard to reach. Do not use it with acid or corrosive products.



**3.2 M / 10,5 FEET
TELESCOPIC LANCE**
Reference 8.35.40.913
**5.4 M / 17,7 FEET
TELESCOPIC LANCE**
Reference 8.35.40.915

A fiberglass lances of 3.2 m and 5.4 m for high spraying. Adaptable to sprayers and compression sprayers (5l to 20l.). Do not use with acids or solvents.



EXTENSION 0.5 M
Reference 8.34.60.943

A fiberglass extension of 0.5 m for horizontal and vertical applications in places that are hard to reach. Light, manageable and easy to assemble.



**IK INOX/STT
COMPRESSED AIR
CONNECTOR**
Reference 8.32.72.804

Brass plug to connect the air compressor.



SPARE PARTS



Extend the service life of your sprayer easily replacing parts

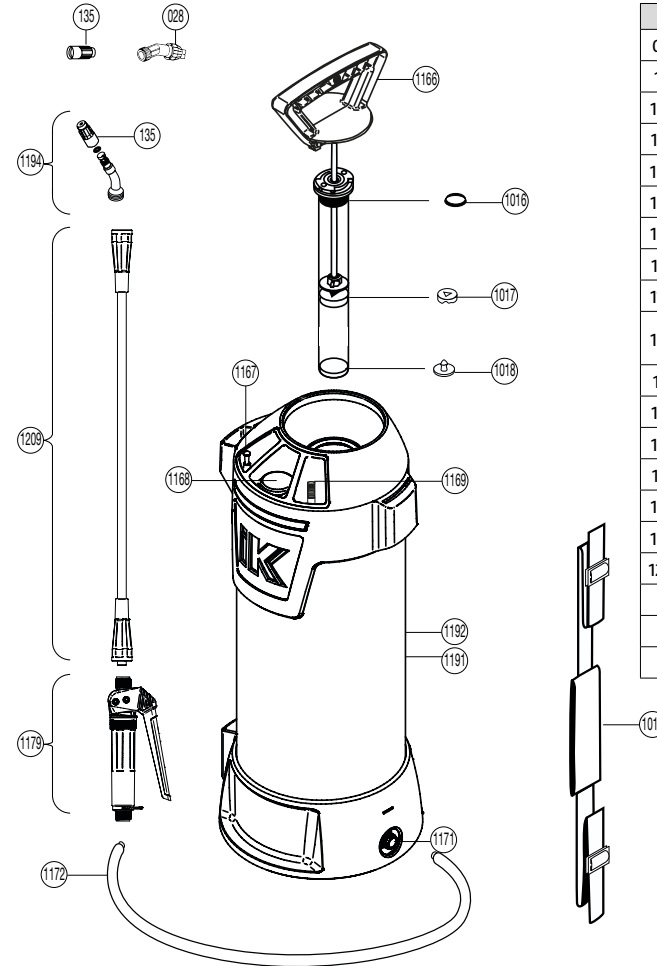

N.	COD.	Q	SPARE PARTS NAME
028	8.34.44.815.1	1	COMPLETE ELBOW
135	8.39.02.323	2	NOZZLE Ø 1
1016	8.38.11.303	1	O-RING
1017	8.38.11.314.1	1	COLLAR SEAL
1018	8.38.05.314.2	1	VALVE
1019	8.38.12.802.2	1	BELT
1166	8.32.72.601	1	PUMP COMPLETE
1167	8.32.72.602	1	SAFETY VALVE
1168	8.32.72.603	1	PRESSURE GAUGE
1169	8.32.72.604	1	INOX/SST 10 AIR CONNECTOR
1171	8.32.72.605	1	COMPLETE ADAPTER
1172	8.32.72.835	1	HOSE
1179	8.18.75.816	1	COMPLETE HANDLE
1191	8.32.73.801	1	INOX/SST 6 TANK
1192	8.32.74.801	1	INOX/SST 10 TANK
1194	8.32.72.803	1	ELBOW WITH NOZZLE
1209	8.32.72.828	1	LANCE TUBE
	8.32.74.200	1	INSTRUCTION SHEET
	8.32.74.201		INOX/SST 10 PACKAGING
	8.32.73.201		INOX/SST 6 PACKAGING